

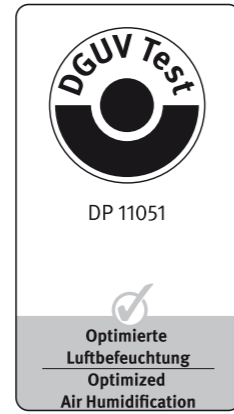

## How you benefit

- Extremely quiet**  
 The brand new nozzle technology brings the noise level to below the recommended maximum value to ensure concentration in the office environment.
- Nano-fine atomisation**  
 The special Nano-nozzle generates a spray pattern which is absorbed invisibly into the room air within a fraction of a second and offers the highest possible level of efficiency.
- Completely hygienic**  
 The 100% hygiene, operating reliability and high performance provided by the NanoFog Evolution atomiser are guaranteed with the unique DRAABE full-service maintenance concept.
- Minimal dimensions**  
 The NanoFog Evolution is as small as the size of your fist and integrates discretely into any room layout.
- With individual swivel function**  
 The atomisers can be swivelled both horizontally and vertically for individual positioning in the room.
- Compatible**  
 The NanoFog Evolution can be combined with all DRAABE high-pressure atomisers.



## Humidification and water treatment

### When you need humidity

**Help:**  
 Requirements are determined together with our specialist consultants. Technical alternatives are presented and discussed. A water analysis is carried out.

**Engineering:**  
 Your individual system is designed by our planning department and developed in CAD. You receive your tailor-made system.

**Service:**  
 Our customer service department performs system start-up while providing field training to your staff.



# NanoFog Evolution Air Humidification



DRAABE Industrietechnik GmbH  
 Schnackenburgallee 18  
 22525 Hamburg  
 Germany  
 Tel.: + 49 40 - 85 32 77 - 0  
 Fax: + 49 40 - 85 32 77 - 44  
 E-Mail: draabe@draabe.com  
 Internet: www.draabe.com

# The Air Humidification System | NanoFog Evolution

## As fine as possible - as small as required

The NanoFog Evolution is the perfect system for all areas of application requiring microfine atomisation, low operating noise levels and an attractive design. The dimensions of the NanoFog Evolution have been cut down to the absolute minimum to ensure that its integration within the room is as

discrete and inconspicuous as possible. Small rooms, low ceilings, low humidity requirements or sensitive production and work rooms – the NanoFog Evolution operates almost invisibly to create optimal humidity in the room.

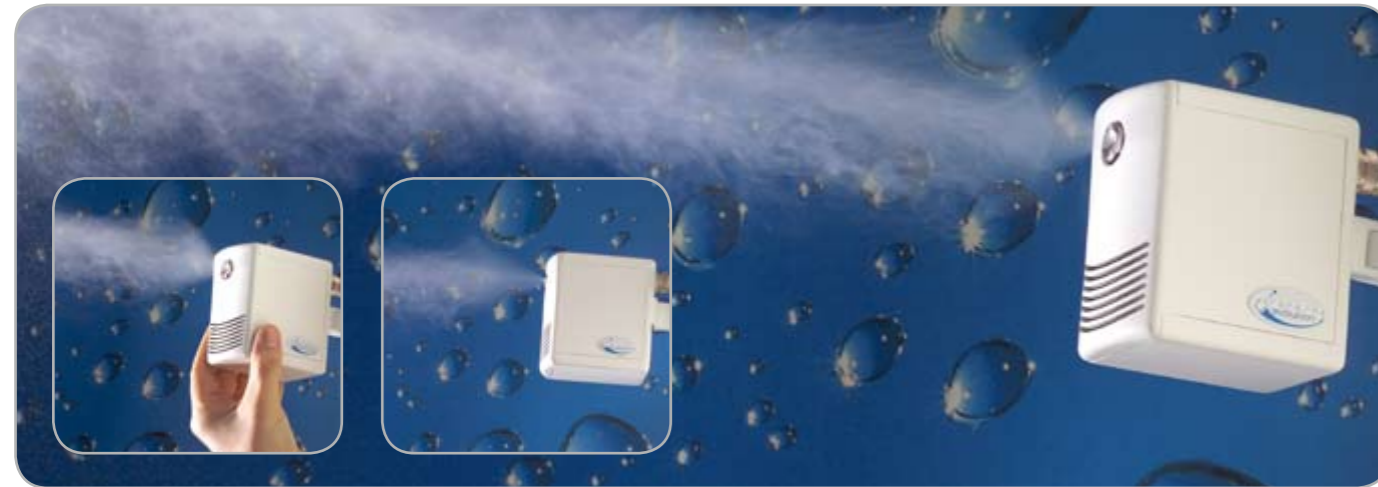

## Design

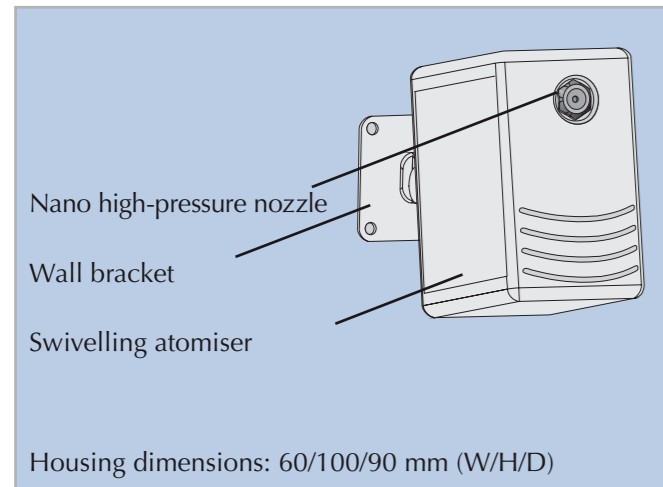

## Technical details

Technical details	NanoFog Evolution
Capacity (max)*	3 kg / h
Operating pressure	85 bar
Droplet size (Sauter)	< 15 µ
Regulation range	10 – 90% r.H.
Power supply	230 Vac, 24 Vdc
Power consumption	8 W
Weight	400 g

\*Performance depends on the nozzles used

# Evolution

## System schematic

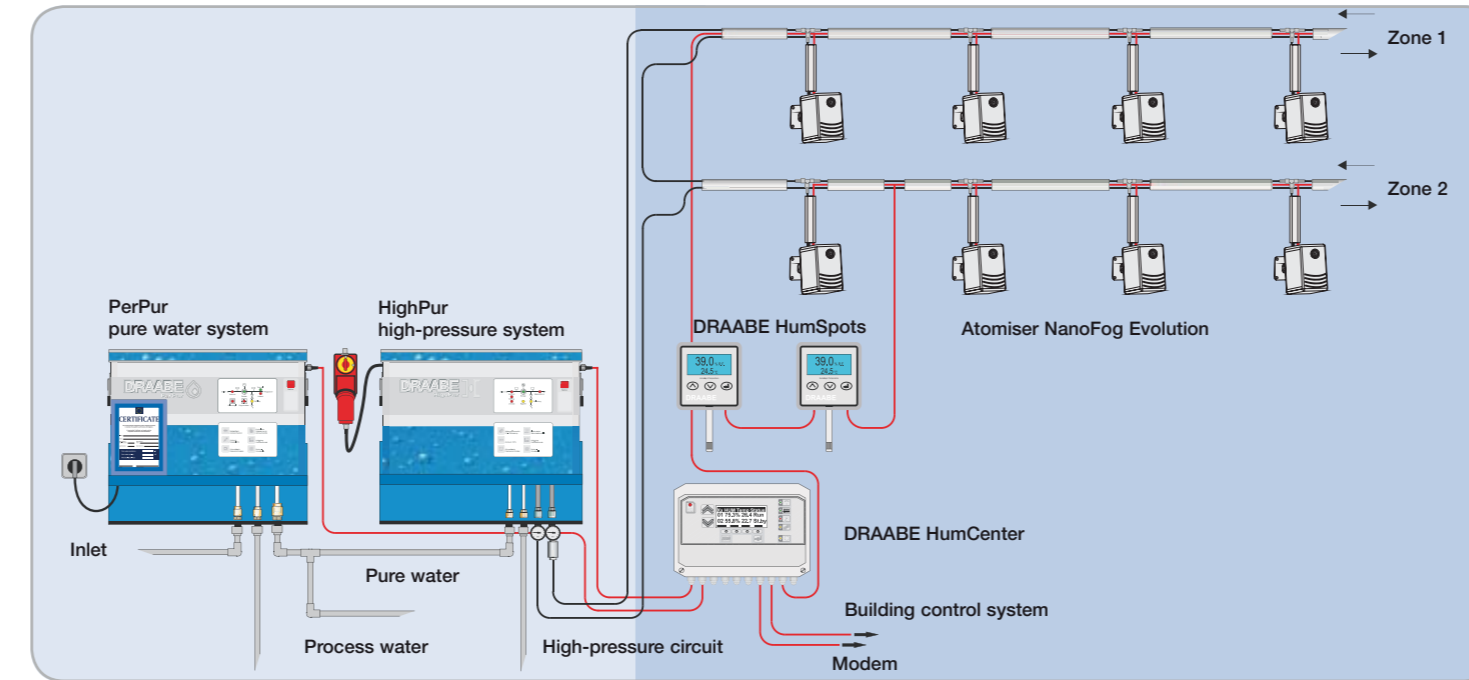

## The high-pressure system HighPur

The centrally installed high-pressure system generates the pulsation pressure needed for the ultra-fine atomising. The entire system is installed in a small portable container, which can be easily replaced during maintenance.



## Technical details

Technical details	HighPur 60	HighPur 120	HighPur 200
Capacity	60 kg/h	120 kg/h	200 kg/h
Operating pressure	85 bar		
Dimensions	600 x 400 x 400 mm		
Weight	approx. 40 kg		
Power consumption	0,72 kw / 400 V3		

## How you benefit

- Output adapts automatically
- Stainless steel technology for partially demineralised water (R/O water)
- DRAABE BioSafe germ elimination system
- Automatic rinsing system for the pipe network
- 24-hour call-out

# HumSpot and HumCenter

## Right to the point!

The DRAABE HumSpot controls and monitors the humidification of the individual zones (e.g. different rooms, work areas). The user-friendly menu navigation and illuminated colour display guarantee a high level of operating comfort.

## How you benefit

- Precise activation of the air humidifier when humidification falls below the set desired humidification level
- High measuring precision using digital, capacitive humidification measurement technology
- Permanent status display of relative humidity and room temperature

DRAABE HumSpot



## Everything under control

As a central control system for the entire air humidification system, the DRAABE HumCenter monitors, controls and analyses all humidification zones and the function of the Pur Container.

## How you benefit

- High level of operating reliability through permanent status display and monitoring of all zones and Pur Systems (**unit protection**)
- Clear display of malfunctions and service messages
- Extensive analysis functions with long-term data storage
- Connection and data transfer to building services management systems possible

DRAABE HumCenter

